

# Runoff Behavior on Urban Road Intersection based on Flow Profile Simulation

*by* Unmer JURNAL KEU

---

**Submission date:** 01-Dec-2023 12:12PM (UTC+0700)

**Submission ID:** 2243941375

**File name:** 6\_32.pdf (522.79K)

**Word count:** 5998

**Character count:** 28154

## Runoff Behavior on Urban Road Intersection based on Flow Profile Simulation

Laksni Sedyowati<sup>1\*</sup>, Turijan<sup>1</sup>, Suhardjono<sup>2</sup>, Ery Suhartanto<sup>2</sup> and Mohammad Plichin<sup>2</sup>

<sup>1</sup> Civil Engineering Department, University of Merdeka Malang

<sup>2</sup> Water Resources Engineering Department, University of Brawijaya

\* Corresponding Author, Email: [laksni.sedyowati@unmer.ac.id](mailto:laksni.sedyowati@unmer.ac.id)

Received: Aug 7, 2016; Accepted: July 9, 2017

**Key words:** Overland flow, Flow profile, Backwater, Road intersection, Low impact development, Storm water management

**Abstract:** There have been various technologies developed to solve the inundation problem that occurs in almost all urban areas. Some of these technologies, such as low impact development (LID), are developed through the concept of source control. The first step of LID practice is to know the runoff behavior on a certain surface of an area, following that, the LID practice is then designed. One of the objectives of LID is to decrease inundation depth on the road. This study aims to learn the profile and behavior of storm water flow along roads before they reach an intersection of a road system in Purwanto region, Malang City, Indonesia. The study design consisted of field measurements and analytical activities as follows: determination of the independent and dependent variables; field measurements and data collection; simulation of flow profiles with various return periods of rainfall using Hydraulic Simulation Model HEC-RAS ver. 4.1; and verification of the simulation result of flow profiles using observation data. This research concluded that slopes on the branch road and runoff discharge on the main road significantly influenced flow depth at the road intersection. The relationship was expressed by power equations. In contrast, the runoff velocity at the branch road was more influenced by the discharge on the branch road and the main road, and the relationship followed a linear equation. A further study is required to decrease the runoff discharge on the road using LID technology such as concrete block pavement as a replacement for asphalt pavement.

## 1. INTRODUCTION

### 1.1 Background

As a consequence of urbanization, cities have undergone huge developments in order to facilitate settlements with housing, office buildings and shopping malls, roads, schools, and other public facilities. The availability of open space in urban areas decreases as a result of the development. This causes a reduction of the soil's ability to absorb rain water, so that the runoff depth and peak discharge increases and the peak

time becomes shorter (Olivera & DeFee, 2007). Therefore, urban planning should be based on a green city approach (Wikantiyoso & Tutuko, 2013).

In the last few decades, there has developed a new concept known as source control, which aims to control runoff at its source or in its surroundings (Jones, 2001). Low impact development (LID) is an alternative to source control implementation. One of the technologies associated with LID is the use of porous paving (Guillette, 2010), which is as an alternative road paving and provides many advantages (Yi, Yeo, & Kim, 2005). In particular, concrete block paving can slow surface runoff, particularly on steep slopes (Sedyowati et al., 2017). The research indicates that an increase in surface slope angle leads to an increase in friction force, so that water flowing downstream will be delayed and the inundation depth can be minimized. The first step of LID is the analysis of runoff behavior through a certain surface over a given area. Following that, the LID is then designed.

As runoff depth increases, it directly causes flooding and inundation (Harisuseno, Bisri, & Yudono, 2012). Changes in surface characteristics also have a direct impact on the characteristics of hydrology and hydro-metrology (Huong & Pathirana, 2013). Unfortunately, in Indonesia and elsewhere, increasing runoff discharge has not been followed by an improvement in the capacity of drainage systems. During every rainy season, affected major cities, particularly those in Indonesia, experienced inundation with an average depth of 20-40cm. This condition interferes with societal activity and causes problems, especially for road users.

However, the road itself can serve as a floodway (Melbourne Water Technical Working Group, 1996). Floodways are sections of roads which have been designed to be submerged under floodwater during relatively low average recurrence interval (ARI) floods (Department of Transport and Main Roads, 2010). They provide passage across a shallow depression that is subject to flooding, and they are specifically designed to resist the damaging effects of submersion (Smith, 2006).

A study conducted on some major roads in the city of Malang, East Java, found that inundation usually occurred where roads intersected at lower elevations. However, inundation did not always occur at every intersection. At junctions with larger differences of longitudinal slope, there was higher inundation. The condition was thought to be a backwater effect that resulted from the joining of two or more surface flows at the road intersection (Sedyowati et al., 2015). However, further information is required about the flow velocity and change in runoff depth along the road in order to design effective storm water management.

## 1.2 Problem statement

The urban drainage system in Malang and its surroundings areas has been overwhelmed by a number of problems. In spite of the fact that Malang is a plateau region, during every rainy season there are certain areas, especially at road intersections, that tend to always flood at a depth of 40-60cm, exceeding the maximum permitted depth of 30cm (Melbourne Water Technical Working Group, 1996). This condition was thought to be caused by backwater flow. The main problems this study aims to resolve are as follows:

- 1) What is the runoff profile upstream of a road intersection?
- 2) What is the runoff velocity and flow depth before the intersection?
- 3) How is the runoff velocity and flow depth influenced by road slope and runoff discharge at the intersection?

### 1.3 Objectives

The main objective of this study is to analyze the runoff profile and behavior at road intersections, with a major review of the slope factor. To achieve the main objective, this study is also designed with several specific objectives, as follows:

- 1) To learn the runoff profile upstream of an intersection.
- 2) To learn the runoff velocity and flow depth before an intersection.
- 3) To learn the effects of road slope and runoff discharge on runoff velocity and flow depth at the intersection.

## 2. LITERATURE REVIEW

In the last few decades, streets, in downtown or residential areas, have also functioned as integral components of the major drainage system when pipe and channel capacities have been exceeded (Smith, 2006). Flow velocity and flow depth limits shall be considered with regard for the safety of children and stability of cars. Car stability is significant because of the potential for increased flood levels due to floodway blockage. The recommended safety limits for road intersections are  $V_{av}.d_{av} \leq 0.35$  m<sup>2</sup>/s and  $d_{av} \leq 0.30$ m, (using the cross-section at the kerb on the downstream side of the intersection on the floodway route, where  $V_{av}$  is the average velocity channel flow, and  $d_{av}$  is the average flow distance in the channel network), subject also to  $d_{max} < 0.30$  m measured at the intersection point of the road centerline with the crown. Floodway hydraulics may be determined using Manning's Equation (Melbourne Water Technical Working Group, 1996).

A diffusion wave numerical model was used to simulate storm water runoff at super elevation transitions. It was found that maximum ponding depth did not depend significantly on the longitudinal gradient, but the location of maximum ponding depth was very sensitive to it, moving from the outside pavement edge for small longitudinal slopes, to the center of the roadway for moderate slopes, and to the inside pavement edge for large longitudinal gradients (Charbeneau, Jeong, & Barrett, 2008). A Laser Mobile Mapping System (LMMS) made it possible to identify sinks on the roadside, locations where water flow accumulated and potentially entered the road. In addition, the method was used to analyze the surface flow over the road's surface. The new method has been demonstrated on a stretch of 153 meters along the Galician mountain road (Wang et al., 2014).

Simulating homogeneous and non-homogeneous network types to estimate the effect of road networks, and building groups with the use of a two-dimensional runoff flow model and a one-dimensional slot-model, can be used to simulate ground surface runoff flow and sewer pipe flow, showing that a non-homogeneous case could calculate more reasonable results (Lee et al., 2016). Simulation in this study is performed with the use of a KINEROS-based hydrology model, using Geographical Information Systems (GIS) software.

### 3. MATERIAL AND METHOD

#### 3.1 Research Location

In this study, observation was undertaken in Purwantoro region, Malang City, Indonesia. The study area included Sulfat Highway and a road system at the Taman Sulfat residential area that had some intersections. There was a total of ten road intersection observation points located in the eastern part of the Taman Sulfat residential area. Each intersection consisted of two roads, namely Puskesmas from the north and Taman Sulfat (TS) from the west. The ten road intersections were defined as TS1, TS3, TS5, TS7, TS9, TS11, TS13, TS15, TS17, and TS19. The lowest area at the eastern part, which was the outlet of runoff for the whole study area, was around TS 13, TS 15 and TS 17. The major land cover at the study area was houses, roads equipped with drainage channels, open space covering about 10% of the study area. Formerly, the study site was farmland with an irrigation system. Along with the development of the city, the area was converted into medium density residential areas.

Figure 1 presents the situation map of the study area. It can be seen that the runoff flows from west to east and ends in the south of the eastern part of the observation area.

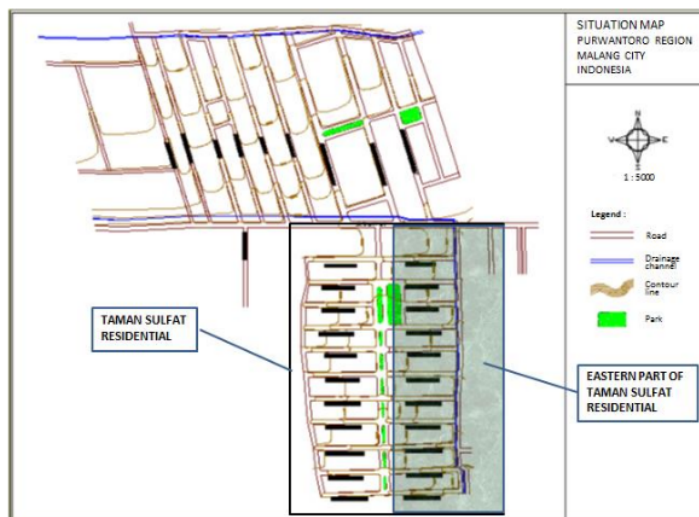

Figure 1. Situation map of the study area

#### 3.2 Methodology

This study consisted of observation and data collection in the field, analysis of flow profiles using a hydraulic model, and development of the relationship function between road slope, flow velocity, and flow depth at various road intersections. The modelling data was then verified by the field observation data based on certain conditions in accordance with rainfall events.

The concept of flow in open channels with a wide cross-section was used to analyse the runoff flow on the road. Geometrical data of the roads included cross-sectional and longitudinal slopes. The data was obtained

through direct measurements in the field. Flow profile data resulting from the backwater phenomenon included data of flow velocity and flow depth. The data was obtained using HEC-RAS hydraulic model version 4.0. Verification was done using the data model of water level observations from several rain events. The intersection observed was between a residential street and the main road in the Bhumi Purwanto Malang housing area, which was an outlet of surface runoff.

### 13 3.2.1 Data Collection

There are two kinds of data used in this study, primary data and secondary data. The primary data consists of topographic maps, road geometry and inundation depths. As it was not possible to obtain a topographic map of the study area at a scale of 1: 10,000, direct measurements were taken using a theodolite. The road geometry data includes cross and longitudinal sections. Cross-section measurements were performed on each interval of 20m. Measurements of the cross and longitudinal profiles were obtained by passing water. Water level data was obtained by direct measurements at points of observation that experienced inundation during the rainy season in the study period.

The secondary data consisted of daily rainfall data from three rainfall stations, namely Abdul Rahman Saleh Station, Ciliwung Station and UB Station. Rainfall intensity data is determined from the maximum daily rainfall data analyses.

### 3.2.2 Calculation of runoff discharge

9  
Runoff discharge was calculated using the Rational Method. The maximum daily rainfall at various return periods was estimated following the Log Pearson III distribution. After that, the discharge drainage system was identified based on the network of drainage systems in the study area.

### 3.2.3 Simulation of runoff profile

Simulation of the runoff profile, using the HEC-RAS hydraulic model version 4.1, was conducted to determine the flow profile before the intersection center. The simulation was undertaken during various return periods of rainfall at various road slopes. This step was also used to determine the length of the backwater curve from the intersection to a point upstream, so that it is possible to see the spread of inundation that occurs at the return periods for various rainfall periods and various slopes.

This activity consisted of several stages: first was the preparation of geometric data and flow rates at the various return periods of rainfall, then data input and running the program to achieve the defined boundary conditions; secondly, the hydraulic model test data was processed to obtain flow depths at the road intersection across the rainfall periods; thirdly, the calibration factor had to be determined using field measurement data and water level observations. This activity was intended to ensure that the data could be used with HEC-RAS software, and, in the case of deviations, that it could be adjusted using the calibration factor. Lastly was viewing the results. Several output features were available under the view option from the main window. These options included cross section plots, profile plots, rating curve plots, X-Y-Z perspective plots, tabular output at specific locations

(Cross Section Table), tabular output for many locations (Profile Table), and the summary of errors, warnings, and notes.

Boundary conditions were required in order to perform the calculations. If a subcritical flow analysis is going to be performed, then only the downstream boundary conditions are required. If a supercritical flow analysis is going to be performed, then only the upstream boundary conditions are required. If a mixed flow regime calculation is to be performed, then both upstream and downstream boundary conditions are required (US Army Corp of Engineers, 2010).

### 3.2.4 Verification of Simulation Result

Verification was conducted to ensure that the model was representative of all of the existing parameters corresponding to the basic theory. In this research, verification was performed using the data model of water level observations based on several rainfall events. Observation data was sourced from the intersection as mentioned above, particularly at the outlet of surface runoff for the entire study area. The data included rainfall intensity, rainfall duration and inundation depth at the center of the intersection. The center of the intersection was the lowest point of Taman Sulfat road at each intersection.

## 4. RESULTS AND DISCUSSION

### 4.1 Road system discharge

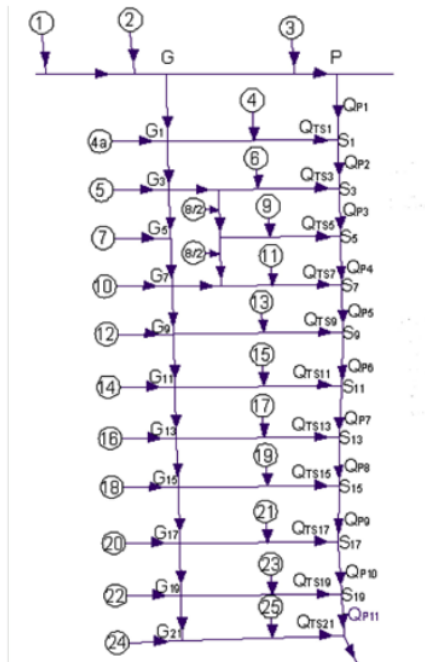

Figure 2. Road system at the study area

Based on the condition of the road network in the study area, the road system discharge network was made, as illustrated in Figure 2. First, the amount of discharge runoff that flows in each catchment was calculated. The catchment boundaries were defined as the streets in the scheme. Runoff discharge and discharge from the road system were calculated at various return periods that were 2, 5, 10, and 25 years respectively. Calculation of runoff discharge can be seen in Table 1, below. P stands for Puskesmas, which was the main road, and TS stands for Taman Sulfat, which was the branch road.

Table 1. Maximum Design Rainfall using Log Pearson III Method

Intersection Point	Road Segment	Discharge of Road System (m <sup>3</sup> /s), in Return Period (T) year							
		2	5	10	25	50	100	200	1000
S1	P1	2.69	3.17	3.44	3.78	3.97	4.17	4.36	5.46
	TS1	0.69	0.81	0.88	0.97	1.02	1.07	1.12	1.40
S3	P2	3.38	3.97	4.33	4.75	4.99	5.24	5.48	6.85
	TS3	0.43	0.51	0.55	0.61	0.64	0.67	0.70	0.88
S5	P3	3.81	4.48	4.88	5.36	5.63	5.91	6.18	7.73
	TS5	0.17	0.20	0.22	0.24	0.25	0.27	0.28	0.35
S7	P4	3.98	4.69	5.10	5.60	5.88	6.18	6.46	8.08
	TS7	0.16	0.18	0.20	0.22	0.23	0.24	0.25	0.32
S9	P5	4.14	4.87	5.30	5.82	6.11	6.42	6.71	8.40
	TS9	0.39	0.46	0.50	0.55	0.58	0.61	0.64	0.80
S11	P6	4.53	5.33	5.81	6.37	6.69	7.03	7.35	9.19
	TS11	0.35	0.41	0.45	0.49	0.52	0.54	0.57	0.71
S13	P7	4.88	5.75	6.25	6.86	7.21	7.57	7.92	9.90
	TS13	0.24	0.28	0.30	0.33	0.35	0.37	0.38	0.48
S15	P8	5.12	6.03	6.56	7.20	7.56	7.94	8.30	10.39
	TS15	0.23	0.28	0.30	0.33	0.35	0.36	0.38	0.48
S17	P9	5.36	6.30	6.86	7.53	7.91	8.30	8.68	10.86
	TS17	0.26	0.31	0.34	0.37	0.39	0.41	0.43	0.53
S19	P10	5.62	6.61	7.20	7.90	8.30	8.71	9.11	11.40
	TS19	0.28	0.32	0.35	0.39	0.41	0.43	0.45	0.56
	P11	5.89	6.94	7.55	8.29	8.70	9.14	9.56	11.96

Discharge from the road system was determined by adding the discharge runoff captured by each road, corresponding to the lane of the road network. Table 1 can be explained as follows: at road intersection point S15, between P8 and TS 15 segments, the runoff discharges were significantly different. Runoff on the Puskesmas road was 2.5 times larger on average than on the Taman Sulfat road. Therefore, Puskesmas road served as the main channel and Taman Sulfat road served as the tributary. This condition also applied to other intersections.

## 4.2 Simulation data

Table 2 presents the data from the Hydraulic Simulation Model HEC-RAS ver. 4.1 with the 2-year flood design. The data was taken from five intersections in the downstream part of the road network system that represented the higher inundation. The intersections chosen were also at the lowest area where all runoff from the upper area at the Purwantoro region (Figure 1) accumulated.

The data in Table 2 was sorted from downstream to upstream. Table 2 indicates that the intersection on Puskesmas 10 and Taman Sulfat 17 had the largest flow depth and lowest velocity, and the Froude number was almost the same as the intersection on Puskesmas 11 and Taman Sulfat 19. Road slope data was calculated by using bottom elevation data; according to that



data, it seems that runoff velocity and flow depth might be influenced by road slope and runoff discharge.

Table 2 also indicates that the runoff discharge on the main road was much greater than the discharge on the branch road. The runoff on the main road slowed the flow from the branch road to the main road, especially at the intersection located at the end of the main road, where the discharge was greatest and its flow depth was at its maximum.

Table 2. Simulation data at five intersections with higher inundation with 2-year flood design

Road segment	Section	Discharge (m <sup>3</sup> /s)	Bottom elevation (m)	Water level elevation (m)	Water depth (m)	Velocity (m/s)	Froude number
Puskesmas 11	35	8.29	440.73	441.24	0.51	1.21	0.56
Puskesmas 11	34	8.29	440.58	441.01	0.43	1.38	0.71
Puskesmas 11	33	8.29	440.33	440.80	0.47	1.28	0.62
Tmn Sulfat 19	12	0.39	440.73	441.32	0.59	0.09	0.04
Tmn Sulfat 19	6	0.39	440.39	441.32	0.93	0.05	0.02
Tmn Sulfat 19	1	0.39	440.13	441.32	1.19	0.03	0.01
Puskesmas 10	32	7.90	440.79	441.43	0.64	1.10	0.44
Puskesmas 10	31	7.90	440.75	441.36	0.61	0.92	0.38
Puskesmas 10	30	7.90	440.74	441.25	0.51	1.13	0.52
Tmn Sulfat 17	12	0.37	440.96	441.49	0.53	0.09	0.04
Tmn Sulfat 17	6	0.37	440.52	441.49	0.97	0.05	0.02
Tmn Sulfat 17	1	0.37	440.25	441.49	1.24	0.04	0.01
Puskesmas 9	29	7.53	440.88	441.58	0.70	1.10	0.44
Puskesmas 9	28	7.53	440.84	441.51	0.67	0.97	0.39
Puskesmas 9	27	7.53	440.79	441.43	0.64	1.03	0.43
Tmn Sulfat 15	12	0.33	441.27	441.64	0.37	0.13	0.07
Tmn Sulfat 15	6	0.33	440.89	441.64	0.75	0.06	0.02
Tmn Sulfat 15	1	0.33	440.78	441.64	0.86	0.05	0.02
Puskesmas 8	26	7.20	441.04	441.70	0.66	0.71	0.29
Puskesmas 8	25	7.20	441.01	441.66	0.65	0.74	0.30
Puskesmas 8	24	7.20	440.92	441.58	0.66	1.13	0.46
Tmn Sulfat 13	12	0.33	441.52	441.74	0.22	0.19	0.14
Tmn Sulfat 13	6	0.33	441.17	441.73	0.56	0.08	0.04
Tmn Sulfat 13	1	0.33	440.95	441.73	0.78	0.06	0.02
Puskesmas 7	23	6.86	441.30	441.87	0.57	0.93	0.39
Puskesmas 7	22	6.86	441.19	441.78	0.59	1.01	0.46
Puskesmas 7	21	6.86	441.09	441.69	0.60	1.00	0.44
Tmn Sulfat 11	12	0.49	441.83	441.93	0.10	0.37	0.43
Tmn Sulfat 11	6	0.49	441.37	441.91	0.54	0.12	0.05
Tmn Sulfat 11	1	0.49	441.09	441.91	0.82	0.08	0.03

### 4.3 Flow depth characteristics

Figures 3(a), (b) and (c) show the cross sectional plot of the road intersection obtained from the Hydraulic Simulation Model HEC-RAS ver. 4.1. The road intersection was in the downstream part of the road network, namely Taman Sulfat 15. The plot describes three points of flow depth at the branch road (tributary), namely RS 12, RS 6 and RS 1, where RS 12 was the upper part. It can be seen that towards the downstream direction, the flow depth increased gradually and the flow profile formed a backwater curve.

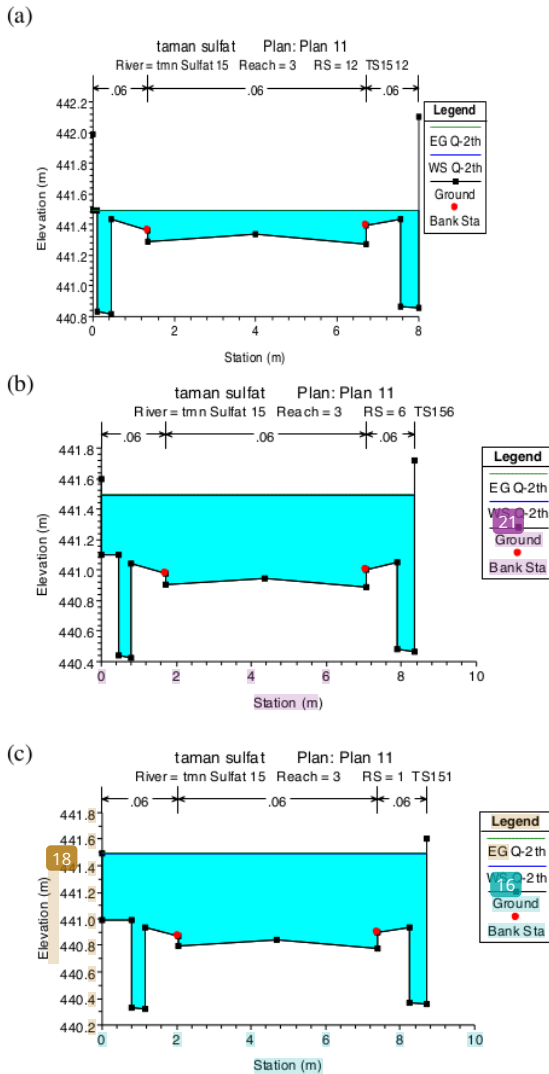

Figure 3. Cross sectional plot of the road intersection at Taman Sulfat 15

The water surface elevation at the three points (Figure 3) were almost all the same. It indicated that the runoff flow from Taman Sulfat was influenced by the runoff flow from Puskemas (the main road). It meant that the flow depth at the main road was greater than at the branch road. It also indicated that the main road delivered runoff from other catchment areas at the upper end of the observation site.

#### 4.4 Runoff velocity behavior

There were two series of velocity data at each intersection. The first set of data was collected at points along the main road, whereas the second set of data was collected at three points along the branch road. Table 2 shows the velocity data at the main road, namely Puskesmas, and the velocity data at the branch road, namely Taman Sulfat. It can be seen that along the

branch road the velocities do not always reach close to zero at every intersection. This means that a backwater curve occurred only on some road intersections with certain criteria. In contrast, the velocities recorded on Puskesmas road were much greater than at the branch road. This phenomenon was caused by the difference in the runoff source; at the branch road, the source was from local rainfall, while at the main road (Puskesmas road) the source was not limited to local rainfall. The major runoff was from other catchments at the upper end of the Taman Sulfat residential area. This happened because there was no source control on those locations. Runoff was flowing down to the lower area through Puskesmas road, which served as a huge channel.

In line with the velocity, the Froude number had similar characteristics. The Froude number at the center of the intersection was close to zero. This showed that the flow from the direction of the branch road had stagnated and was not flowing properly. While the Froude number at the main road was greater, it remained a subcritical flow.

### 4.5 Analyses of road slope at intersection

As mentioned above, road slope at intersections was calculated by subtracting water level elevation from bottom elevation, and was then divided by the distance between the two points. The results are presented in Table 3.

Table 3. Road slope at five intersections in lowest area

Road segment	Average slope	Road segment	Average slope
Puskesmas 11	0.0188	Tmn Sulfat 19	0.0066
Puskesmas 10	0.0029	Tmn Sulfat 17	0.0067
Puskesmas 9	0.0048	Tmn Sulfat 15	0.0045
Puskesmas 8	0.0052	Tmn Sulfat 13	0.0055
Puskesmas 7	0.0089	Tmn Sulfat 11	0.0081

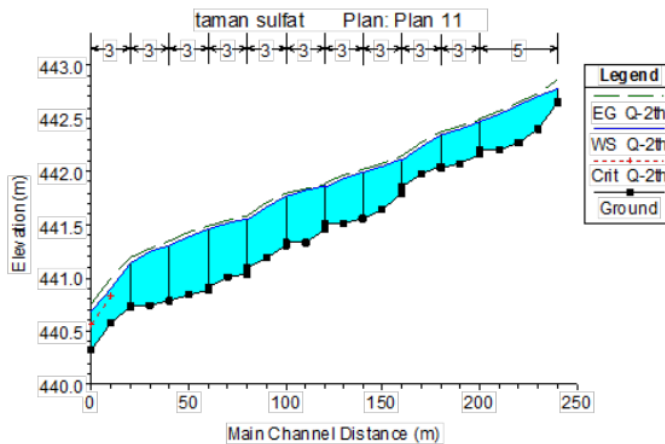

Figure 4. Long section of the main road

Table 3 indicates that there is no specific trend of the slope from the upper to the lower area. The road slope describes the topographical condition of the observed area. Slopes on the branch roads were almost all the same, and were categorized as mild slopes. However, on the main road, the slope slightly fluctuated. In segments Puskesmas 11 and Puskesmas 7, the slopes

were steeper than for the other segments which were almost flat. It seems that greater slope led to an increase in the Froude number. Figure 4 below describes the long section of main road and the configuration of the road.

Figure 4 indicates that there was no backwater curve along the main road. At the end of the road there was a steeper slope which led to a drawdown profile.

#### 4.6 Relationship between road slope, runoff discharge, runoff velocity and flow depth

Based on all the data presented in the tables above, the relationship between all parameters were then analysed using the coefficient of correlation, coefficient of determination, and regression analyses. Table 4 and Table 5, below, show the correlation coefficient and determination coefficient between all parameters. It can be seen that the flow depth of the branch road at the intersection was significantly influenced by the discharge at the main road, and by velocity at the main road and branch road. However, the magnitude of the flow depth can be estimated using the slope of the branch road and discharge on the main road. The relationship was expressed by a power function as shown in Equation 1. The  $R$ -square was 0.90 and the standard error was 0.09.

Runoff velocity on the branch road at the intersection was significantly influenced by runoff discharge on the main road at the branch road, and by flow depth at the branch road. The relationship was expressed by a linear function as shown in Equation 2. The  $R$ -square was 0.99 and the standard error was 0.009. The magnitude of runoff velocity on the main road was significantly influenced by the slope ratio between Puskesmas road and Taman Sulfis road, and by the runoff discharge of Puskesmas road. The relationship was expressed by a linear function as in Equation 3, shown below.

Table 4. Correlation coefficient of all parameters

	Ratio 1	Ratio 2	Slope 1	Slope 2	Q1	Q2	H1	U1
Ratio 1	1.00							
Ratio 2	-0.80	1.00						
Slope 1	0.06	0.11	1.00					
Slope 2	-0.75	0.98	0.32	1.00				
Q1	-0.17	0.14	0.91	0.33	1.00			
Q2	0.01	0.54	-0.17	0.47	-0.36	1.00		
H1	0.34	0.29	0.23	0.32	-0.04	0.87	1.00	
U1	-0.19	-0.24	0.53	-0.11	0.72	-0.90	-0.70	1.00

Table 5. Determination coefficient of all parameters

	Ratio 1	Ratio 2	Slope 1	Slope 2	Q1	Q2	H1	U1
Ratio 1	1.00							
Ratio 2	0.64	1.00						
Slope 1	0.00	0.01	1.00					
Slope 2	0.57	0.95	0.10	1.00				
Q1	0.03	0.02	0.83	0.11	1.00			
Q2	0.00	0.29	0.03	0.22	0.13	1.00		
H1	0.11	0.08	0.05	0.10	0.00	0.76	1.00	
U1	0.04	0.06	0.28	0.01	0.52	0.81	0.49	1.00

where,

Ratio 1 (R1) Slope 1/slope 2

Ratio 2 (R2)	Slope 2/Slope 1
Slope 1 (S1)	Slope of branch road
Slope 2 (S2)	Slope of main road
Q1	Discharge of branch road
Q2	Discharge of main road
H1	Flow depth of branch road
U1	Velocity of branch road
U2	Velocity of main road

The formulas for estimating flow depth and flow velocity at intersections are as follows:

- 1) Formula of flow depth on the branch road at intersection

$$H1 = 0.03(S1)^{0.4}(Q2)^{2.7184} \quad \text{Equation 1.}$$

- 2) Formula of flow velocity on the branch road at intersection

$$U1 = 0.497 + (0.378(Q1)) - (0.072(Q2)) \quad \text{Equation 2.}$$

- 3) Formula of flow velocity on the main road at intersection

$$U2 = (0.085(R2)) + (0.158(Q2)) - 0.257 \quad \text{Equation 3.}$$

The equations above show that runoff on the main road significantly influenced both the flow depth and flow velocity on the branch road and on the main road. To reduce the rate of runoff, especially on the sloping road, paving blocks can be used to replace the standard asphalt pavement (Sedyowati et al., 2017).

## 5. CONCLUSIONS

There was a backwater profile on the branch road at the intersections in which the discharge on the main road was about twenty times greater than on the branch road. However, there was no backwater profile on the main road.

Runoff velocity on the branch road was close to zero. There was a retardance factor when the flow from the branch road flowed to the main road. This factor was led by the greater discharge on the main road. Flow depth on the branch road increased gradually from upstream to downstream before reaching the intersection point.

Flow depth at the road intersection was significantly influenced by the runoff discharge on the main road and slope on the branch road. The relationship was expressed by a power function equation, whereas the runoff velocity at the branch road was more influenced by the discharge on the branch road and the main road, and the relationship followed a linear function.

Further study is required to decrease the runoff discharge on the road using LID technology, such as concrete block paving as a replacement for the asphalt paving. Using this technology, the runoff can be controlled at its source and in its surroundings.

## ACKNOWLEDGEMENTS

This research was financially supported by The Ministry of Research, Technology and Higher Education, Republic of Indonesia, through their

research grant, Penelitian Hibah Bersaing (PHB) 2014-2015. This research was also supported by the Civil Engineering Department, University of Merdeka Malang, especially the Head of Land Surveying Laboratory, and the students who assisted in surveying and mapping the research location.

## REFERENCES

- Charbeneau, R. J., Jeong, J., & Barrett, M. E. (2008). "Highway Drainage at Superelevation Transitions", *Center for Transportation Research* Austin, TX. Center for Transportation Research, The University of Texas at Austin. Retrieved from [http://ctr.utexas.edu/wp-content/uploads/pubs/0\\_4875\\_1.pdf](http://ctr.utexas.edu/wp-content/uploads/pubs/0_4875_1.pdf).
- Department of Transport and Main Roads. (2010). "Floodway Design", *Road Drainage Manual*, Australia. Queensland Government.
- Guillette, A. (2010). "Achieving Sustainable Site Design through Low Impact Development Practices": Low Impact Design Studio (formerly with the Low Impact Development Center). Retrieved from <https://h-gac.com/community/low-impact-development/documents/Achieving-Sustainable-Site-Design-through-LID-Practices.pdf>.
- Harisuseno, D., Bisri, M., & Yudono, A. (2012). "Runoff Modelling for Simulating Inundation in Urban Area as a Result of Spatial Development Change". *Journal of Applied Environment Biology Science*, 2(1), 22-27.
- Huong, H., & Pathirana, A. (2013). "Urbanization and Climate Change Impacts on Future Urban Flooding in Can Tho City, Vietnam". *Hydrology and Earth System Sciences*, 17(1), 379-394.
- Lee, S., Nakagawa, H., Kawaike, K., & Zhang, H. (2016). "Urban Inundation Simulation Considering Road Network and Building Configurations". *Journal of Flood Risk Management*, 9(3), 224-233.
- Melbourne Water Technical Working Group. (1996). "Floodway Safety Criteria". *Melbourne Water Land Development Manual*.
- Olivera, F., & DeFee, B. B. (2007). "Urbanization and Its Effect on Runoff in the Whiteoak Bayou Watershed, Texas". *JAWRA Journal of the American Water Resources Association*, 43(1), 170-182.
- Sedyowati, L., Suhardjono, Suhartanto, E., & Harisuseno, D. (2015). "Flow Profile on Urban Road Intersection Based on the Longitudinal Slope". Proceedings of Narotama International Conference on Civil Engineering (NICCE-2015). Retrieved from <http://fakultasteknik.narotama.ac.id/wp-content/uploads/2015/11/Transportation-Sedyowati-49-56.pdf>.
- Sedyowati, L., Suhardjono, S., Suhartanto, E., & Sholichin, M. (2017). "Runoff Velocity Behavior on Smooth Pavement and Paving Blocks Surfaces Measured by a Tilted Plot". *Journal of Water and Land Development*, 33(1), 149-156.
- Smith, E. R. (2006). "Floodway Design Guide", *MRWA Floodway Design Guide: Structures Engineering of Main Roads Western Australia*. Retrieved from <https://www.mainroads.wa.gov.au/Documents/Floodway%20Design%20Guide.PDF>.
- US Army Corp of Engineers. (2010). "Hec Ras River Analysis System, User's Manual, Version 4.1": US Army Corp of Engineers, Hydrologic Engineering Center, USA.
- Wang, J., Gonzalez-Jorge, H., Lindenberg, R., Arias-Sanchez, P., & Menenti, M. (2014). "Geometric Road Runoff Estimation from Laser Mobile Mapping Data". Paper presented at the ISPRS Annals of the Photogrammetry, Remote Sensing and Spatial Information Sciences, Riva del Garda, Italy.
- Wikantiyoso, R., & Tutuko, P. (2013). "Planning Review: Green City Design Approach for Global Warming Anticipatory". *International Review for Spatial Planning and Sustainable Development*, 1(3), 4-18.
- Yi, J.-E., Yeo, W.-G., & Kim, M.-M. (2005, September 11-16). "Analyzing Stormwater Runoff Decrease Effects by Using Porous Pavements". Proceedings of XXXI IAHR Congress, Seoul, Korea, pp. 1171-1178.

# Runoff Behavior on Urban Road Intersection based on Flow Profile Simulation

## ORIGINALITY REPORT

13%

SIMILARITY INDEX

12%

INTERNET SOURCES

5%

PUBLICATIONS

4%

STUDENT PAPERS

## PRIMARY SOURCES

1	<a href="http://www.scinapse.io">www.scinapse.io</a> Internet Source	2%
2	<a href="http://www.melbournewater.com.au">www.melbournewater.com.au</a> Internet Source	2%
3	Submitted to University of Southern Queensland Student Paper	1%
4	<a href="http://repositories.lib.utexas.edu">repositories.lib.utexas.edu</a> Internet Source	1%
5	Laksni Sedyowati, Eko Indah Susanti. "Effects of Concrete Block Pavement on Flow Retardation Factor", Journal of Applied Engineering Sciences, 2017 Publication	1%
6	<a href="http://repository.tudelft.nl">repository.tudelft.nl</a> Internet Source	1%
7	<a href="http://orcid.org">orcid.org</a> Internet Source	1%

8	Submitted to Universitas Merdeka Malang Student Paper	1 %
9	L Sedyowati, G Chandrarin, G I K Nugraha. "Towards sustainable community: Effort to reduce flood risk and increase well-being in a densely populated flood-prone area", IOP Conference Series: Earth and Environmental Science, 2021 Publication	<1 %
10	soilworks.com Internet Source	<1 %
11	lup.lub.lu.se Internet Source	<1 %
12	repository.kulib.kyoto-u.ac.jp Internet Source	<1 %
13	repository.um.edu.my Internet Source	<1 %
14	Advances in Water Resources and Hydraulic Engineering, 2009. Publication	<1 %
15	journals.pan.pl Internet Source	<1 %
16	Submitted to University of Exeter Student Paper	<1 %
17	www.bafu.admin.ch Internet Source	<1 %



<1 %

18

[apps.planningportal.nsw.gov.au](https://apps.planningportal.nsw.gov.au)

Internet Source

<1 %

19

Lee, S., H. Nakagawa, K. Kawaike, and H. Zhang. "Urban Inundation Simulation Considering Road Network and Building Configurations", *Journal of Flood Risk Management*, 2015.

Publication

<1 %

20

[edoc.mdc-berlin.de](https://edoc.mdc-berlin.de)

Internet Source

<1 %

21

[va.mite.gov.it](https://va.mite.gov.it)

Internet Source

<1 %

22

Haixia Zhao, Xuejun Duan, Becky Stewart, Bensheng You, Xiaowei Jiang. "Spatial correlations between urbanization and river water pollution in the heavily polluted area of Taihu Lake Basin, China", *Journal of Geographical Sciences*, 2013

Publication

<1 %

23

Ninik Catur Endah Yuliati, Dewi Sri Murni, Wisnumurti, Wibowo Ari. "Comparative study of behaviour of reinforced concrete beam-column joints with reference to monolithic and non-monolithic connection", *MATEC Web of Conferences*, 2018

<1 %

24

[acikbilim.yok.gov.tr](http://acikbilim.yok.gov.tr)

Internet Source

<1 %

25

[doczz.es](http://doczz.es)

Internet Source

<1 %

26

"New Trends in Urban Drainage Modelling",  
Springer Science and Business Media LLC,  
2019

Publication

<1 %

27

J. Wang, H. Gonzalez-Jorge, R. Lindenbergh, P.  
Arias-Sanchez, M. Menenti. "Geometric road  
runoff estimation from laser mobile mapping  
data", ISPRS Annals of Photogrammetry,  
Remote Sensing and Spatial Information  
Sciences, 2014

Publication

<1 %

Exclude quotes Off

Exclude matches Off

Exclude bibliography On