

"The role of service performance mediating the effect of management commitment to service quality structure on the reputation of hospitality industry companies in West Java

by Boge Triatmanto

Submission date: 17-Jun-2020 12:13PM (UTC+0700)

Submission ID: 1345217998

File name: ating_the_effect_of_management_commitment_to_service_quality.pdf (366.27K)

Word count: 3935

Character count: 22924

The role of service performance mediating the effect of management commitment to service quality structure on the reputation of hospitality industry companies in West JavaEndang Dwi Amperawati^a, Widji Astuti^{b*} and Boge Triatmanto^b^aStudent of Postgraduate Program, University of Merdeka, Malang, Indonesia^bFaculty of Economics & Business, University of Merdeka, Malang, Indonesia

CHRONICLE

Article history: ¹⁹
 Received: February 10, 2020
 Received in revised format:
 March 20 2020
 Accepted: April 17, 2020
 Available online:
 April 17, 2020

Keywords:

Company's reputation
 Management commitment to service quality
 Service performance

ABSTRACT

This study seeks to analyze ¹⁸ the effect of management commitment to service ¹⁷ quality on service performance, the effect of management commitment to service ⁹ quality on company's reputation, the effect of service performance to company's reputation, and the effect of management commitment to service quality on company's reputation through service performance. The study employed structural equation ³ modeling (SEM) as an analysis technique. The analysis shows that management commitment to service ²¹ quality had a significant and positive effect on service performance, management commitment to service quality had a significant and positive ³³ effect on the company's reputation, service performance affected the company's reputation and management commitment to service quality affected the company's reputation through service performance.

© 2020 by the authors; licensee Growing Science, Canada

1. Introduction

In the hospitality service industry, the company's reputation is thought the key factor in the evaluation of overall strength by customers upon hearing the company's name and seeing its label/logo. The company's reputation also displays the company's position in being different from or superior to competitors; it is one of the key elements of intangible resources creating conditions for sustainable competitive advantage (Alvarez Dominguez, 2011). In service products, the value will be fulfilled if management is committed to service quality and has customer-oriented service staff (Chahal & Kumari, 2012; Demirbag, Sahadev, Kaynak, & Akgul, 2012; Lytle & Timmerman, 2006). Management committed for providing quality services to customers will provide support to every service development need accompanying the company's products; thus, the products always meet customers' ever-changing expectations corresponding to environment development. Additionally, committed management will continue to empower the company's human resources because human resource services play a key role; in addition to being a service provider, it is also a display of service performance viewed by consumers, therefore, it is the tip of the spear in the success of products and companies (Demirbag et al., 2012; Lytle & Timmerman, 2006; Triatmanto, Wahyuni, & Respati, 2019). Many studies on the company's reputation (Alvarez Dominguez, 2011; Caruana & Ewing, 2010; Heinberg, Ozkaya, & Taube, 2018; Park, 2019) prove that corporate reputation is influenced by management commitments to service quality and this is also shown by Cojocaru (2011). Furthermore, management's commitment to service quality has a positive and significant effect on the company's reputation (Kurd, Medeni, Medeni, & Sagsan, 2017; PourKiani & Tanabandeh, 2016). Mok et al. (2009) define management commitment to service quality as a strong management drive to provide services to the desired target market (Babakus, Yavas, Karatepe, & Avci, 2003; Cronin & Taylor, 1989; Mmutle & Shonhe, 2017). According to Lisch (2014), service performance is the value for services obtained by comparing the services provided with services

* Corresponding author. Tel.: +62 81 1361161
 E-mail address: widji_astuti@yahoo.com (W. Astuti)

received or expected. In other studies, it is found that service performance has a positive and significant effect on the company's reputation (Mmutle & Shonhe, 2017; Selnes, 1993). The research also shows that service performance and the company's reputation significantly affect each other (Jalbani & Soomro, 2017).

This study aims to analyze the effect of management commitment to service quality on service performance, the effect of management commitment to service quality on company's reputation, the effect of service performance to company's reputation, and the effect of management commitment to service quality on company's reputation through service performance

2. Critical Review

2.1 Company's reputation

Reputation is the company's recognition obtained through showing excellence (such as the company's capabilities). Thus, the company will continue to develop the company and to create new products to meet the consumers' needs (Balmer & Gray, 2003; Herbig & Milewicz, 1993; Resnick & Resnick, 2012). Furthermore, Weiss et al. (1999) assert that a reputation is a public view of a company as it is being evaluated globally on its openness, quality, and others; thereby, it can be argued that it is a public view of the company's movement.

2.2 Service Performance

Service performance is assessed by the consumers; they assess the quality of service received (Cronin & Taylor, 1992, 1994, 2013; Parasuraman, Zeithaml, & Berry, 1994). The overall customer assessment of services provided by the company displays the quality of the service more precisely and specifically; the better the company service performance, the higher the level of customer loyalty (Liang, Tseng, & Lee, 2010; Minkiewicz, Evans, Bridson, & Mavondo, 2011; Suliman & Al Kathairi, 2013). Consequently, if the product/service does not meet their needs, does not function satisfactorily, or is not commensurate with the cost, the consumers will be unhappy about their purchase and will likely create this dissatisfaction to several sources, viz. service providers, retailers or even themselves since customers take part in the production and delivery of services. The SERVQUAL model (Service Quality) highlight the importance of customer expectations before purchasing or consuming a service as a reference in evaluating the performance of the service (Parasuraman, Berry, & Zeithaml, 1991; Parasuraman, V, & Berry, 1998; Parasuraman, Zeithaml, & Berry, 2010).

2.3 Management Commitment to Service Quality

Management commitment to service quality is characterized by the extent to which management can create a conducive work climate; if the management can provide greater support, employees will improve their performance and carry out their obligation better (Roca-Puig, Beltran-Martin, & Segarra-Cipres, 2012; Rod & Ashill, 2010; Wang, Qu, & Yang, 2019). The company's commitment shows that it considers the continuation of the relationship with the buyer as it is something that must be well maintained (Morgan & Hunt, 1994). Management commitment to service quality is the manager's effective desire to improve the quality of service units (Hartline, Michael D, 2010). The best indicators of building management commitment to service quality are training, empowerment, and appreciation (Helm, 2011; Lytle & Timmerman, 2006; Polnaya, Nirwanto, & Triatmanto, 2018).

2.4 Hypothesis

- H₁: Management commitment to service quality has a significant and positive effect on service performance.
 H₂: Management commitment to service quality has a significant and positive effect on the company's reputation.
 H₃: Service performance has a significant and positive effect on the company's reputation.
 H₄: Management commitment to service quality affects the company's reputation through service performance.

3. Method

This study was designed with a causality approach analyzing the relationship and influence among the variables: Management Commitment to Service Quality, Customer-Oriented Service Staff, Customer Value, Service Performance, and Company's reputation; therefore, it is safe to say that this is an explanatory research disclosing the causal relationship and testing the research hypotheses.

3.1 Population, Sample dan Sampling Technique

The study population was four-star hotel guests in West Java. The total population in 2018 was 2,536 (Bandung Central Statistics Agency or *Badan Pusat Statistik Kota Bandung*, 2019). The sample was guests staying at four-star hotels when the study was conducted. The sample size was determined based on Slovin and the researchers obtained a sample of 189 respondents. The collected data were analyzed using a multivariate statistical analysis of Structural Equation Modeling / SEM.

4. Results

4.1. Confirmatory Analysis

Confirmatory analysis of exogenous, intervening and endogenous variables have been carried out to confirm whether the observed variables can reflect the analyzed factors, viz. having a model suitability test - the goodness of fit test, significant factor weight, and lambda value or factor loading.

Table 1
Confirmatory Analysis Test Results

Indicator	Latent Variable	Loading Factor	CR	P-value	Description
Management support	Management commitment to service quality	0.87	Fixed	0.000	Valid
Technology investment	Management commitment to service quality	0.67	9.263	0.000	Valid
Servant Leadership	Management commitment to service quality	0.67	10.668	0.000	Valid
Process quality	Service Performance	0.77	11.196	0.000	Valid
Interaction quality	Service Performance	0.81	11.826	0.000	Valid
Environment quality	Service Performance	0.81	Fixed	0.000	Valid
Cost	Service Performance	0.75	10.788	0.000	Valid
Image	Company's reputation	0.87	9.599	0.000	Valid
Identity	Company's reputation	0.77	Fixed	0.000	Valid
Reliability Construct	= 0.933 (cut-off value = 0.7)				Reliable
Variance Extract	= 0.608 (cut-off value = 0.5)				Reliable

Source: Primary data processed, 2019.

Based on the information in Table 1, the factor loading value of each indicator exceeds the cut-off value of 0.5, the probability value (p) is less than or equal to 0.05, the Reliability Construct value of 0.933 is greater than the cut-off value of 0.7, and the Variance Extract value of 0.608 is greater than the cut-off value of 0.5. Moreover, management commitment to service quality indicator showing the highest factor loading value is management support with a value of 0.87, while service performance indicator showing the highest factor loading value is interaction quality and social skills respectively of 0.81, and the company's reputation indicator showing the highest factor loading value is the image with a value of 0.87. These results demonstrate that the indicators tested have good reliability in shaping and operating latent variables of management commitment to service quality, service performance, and the company's reputation.

4.3 Model Suitability Test (Goodness Of Fit)

Based on the literature review and research objectives, the overall structural model is developed as follows:

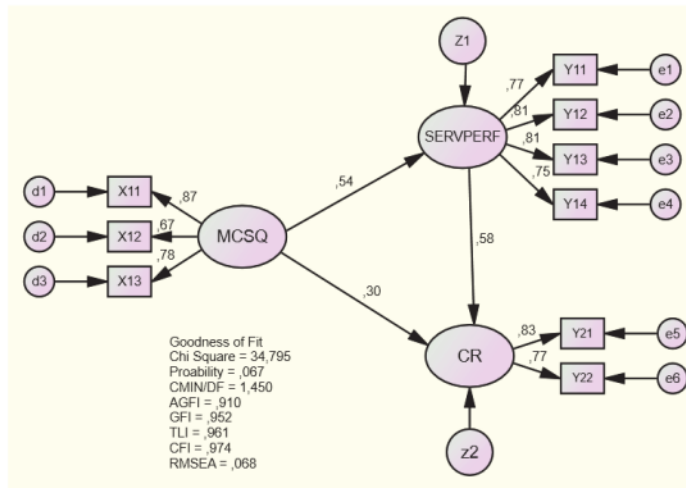

Fig. 1. SEM Analysis Results

According to the AMOS 18 computation for this SEM model, generated goodness of fit indexes is presented in Table 2. Furthermore, the index values are compared with the critical value (cut-off value) of each index. A good model is expected to have the goodness of fit indexes that are greater or equal to the critical value.

Table 2 ¹³
Modification of Goodness Of Fit Structural Model Test Results

Goodness Of Fit Index	Cut-off Value	Model Result	Description
Chi-Square (df = 24)	38.2	34.795	Good
Probability Chi-Square	≥ 0.05	0.067	Good
CMIN/DF	≤ 2.00	1.450	Good
RMSEA	≤ 0.08	0.068	Good
GFI	≥ 0.90	0.952	Good
AGFI	≥ 0.90	0.961	Good
CFI	≥ 0.95	0.974	Good
TLI	≥ 0.95	0.961	Good

Source: Primary data processed, 2019.

³⁰ Viewing the results of the evaluation criteria of Goodness of Fit Indices in Table 2, the evaluation of the model as a whole has met and the model can be accepted.

Table 3
Hypothesis Test

Hip	Variable			Direct Influence		Indirect Influence	Total Influence	Description
	Exogeneous	Intervening	Endogeneous	Coef.	Prob.			
H ₁	³⁵ Management commitment to service quality	Service Performance	-	0.54	0.000*	-	-	Accepted
H ₂	Management commitment to service quality	-	²⁴ Company's reputation	0.30	0.000*	-	-	Accepted
H ₃	-	Service Performance	Company's reputation	0.58	0.000*	-	-	Accepted
H ₄	Management commitment to service quality	Service Performance	Company's reputation	0.30	0.000*	0.31	0.61	Accepted

* significant at $\alpha = 5\%$.

5. Discussion

Management commitment to service quality that can improve service performance is the support reflected in the hotel management; they hire employees having expertise in the respective fields. Service performance is displayed through the interaction quality in which consumers love staying in the hotel because the employees are friendly. Furthermore, the environment quality is reflected through consumers admiring its beautiful exterior arrangement. Employees are required to respond quickly and efficiently in meeting guests' needs. Management commitment to service quality is characterized by the extent to which management can create a conducive work-climate; if management can provide greater support, the employees will improve their performance and carry out their obligations better. Management commitment plays a major part in supporting success in improving hotel service performance. The results of this study support several previous studies stating that management commitment to service quality affects service performance (Ashill, Rod, & Carruthers, 2008; Babakus et al., 2003; Harter & Ferrell, 1996). Nevertheless, the results of this study do not support those of Kiani & Tanabandeh, (2016) stating that management commitment to service quality does not affect service performance. Management commitment to service quality substantially affects the company's reputation. This shows that when carried out continuously, it can improve the company's reputation. Management commitment to service quality is an awareness to improve the quality and operation of the organization; the management selects the strategies for hotels and engages in activities that provide direction to the leader in improving the hotel quality. The management, through its participation in quality development, provides direction and encouragement for employees during the process of providing services. Management commitment to the service standards will be reflected in the quality of service that employees provide. When the quality of service conforms to the expectations of hotel guests, the company's reputation will be improved. Challenges and competition in the business world also affect the industry related to hotel services. Every hotel guest not only expects to receive the checking-in service but the best services the hotel has to offer. (Herbig & Milewicz, 1993) pointed out that reputation is awarded the company's recognition obtained through showing excellence (such as the company's capabilities); thus, the company will continue to develop the company and to create new products to meet the consumers' needs. The results of this study support research conducted by Mmutle & Shonhe (2017) asserting that management commitment to service quality affects reputation. Service performance is displayed through the interaction quality in which consumers love staying in the hotel because the employees are friendly, while the environment quality is reflected through consumers admiring its beautiful exterior arrangement; thus, it can improve the company's reputation. Good service performance is a crucial aspect of determining hotel success, particularly in organizations engaged in services. Service performance is the tip of the spear in seizing opportunities and understanding consumers using the services

offered by the hotel. Service performance is the customer's assessment of the overall excellence or feature of a product or service. In addition, service performance is a benchmark in determining a user's decision in using the services offered by service providers. The services received are utilized to assess service performance because it can be used to evaluate customers' satisfaction; the better a company's service performance, the better the company's reputation. Previous research findings (Cronin & Taylor, 1994, 2013; Parasuraman et al., 1994) show that service performance is assessed by the consumers; they assess the quality of service received. The overall customer assessment of services provided by the company displays the quality of the service more precisely and specifically. Management's commitment to service quality is reflected in management support, investment in technology, and servant leadership. Management commitment to service quality, customer-oriented service staff, and customer value affect service performance; this is illustrated as follows: if the hotel management has hired employees who have expertise in their respective fields, provides alternative ways of payment, ensures that hotel facilities function properly, guarantee the safety of hotel guests, and provides parking space for all hotel guest, the service performance is eventually increased as the cost commensurate additional services; additional room charges are incurred in accordance with the additional facilities. Consumers love staying in the hotel because the additional cost of facility reservation is affordable; this will improve the company's reputation.

6. Conclusion and suggestions

Management commitment to service quality affects service performance. In this research, it is shown by the management support in ensuring that guests are provided with parking spaces. This can display the service performance through the interaction quality as consumers love staying in the hotel because the employees are friendly and trustworthy, while the environment quality is reflected through consumers admiring its beautiful exterior arrangement. Service performance affects the company's reputation. This finding explains that interaction quality is depicted from liking staying at this hotel because employees are friendly to guests and environmental quality is depicted from liking at this hotel because of the beautiful exterior arrangement, this can enhance the company's reputation as reflected in the image reflected by liking at this hotel because hotel employees can be trusted. Service performance is a strengthening (mediating) management commitment to service quality, toward the company's reputation. It means that the company's reputation (image) can be improved if the hotel management supports providing parking space for all hotel guests. It is expected that future researchers conduct further exploration related to variables affecting corporate reputation, especially in the hospitality industry to broaden and generalize research results. Research in other service industries is recommended as well. Practitioners in the hospitality industry are advised to apply the research results.

References

- Alvarez Dominguez, A. (2011). The impact of human resource disclosure on corporate image. *Journal of Human Resource Costing & Accounting*, 15(4), 279–298.
- Ashill, N. J., Rod, M., & Carruthers, J. (2008). The effect of management commitment to service quality on frontline employees' job attitudes, turnover intentions and service recovery performance in a new public management context. *Journal of Strategic Marketing*, 16(5), 437–462.
- Babakus, E., Yavas, U., Karatepe, O. M., & Avci, T. (2003). The effect of management commitment to service quality on employees' affective and. *Journal of the Academy of Marketing Science*, 31(3), 272–286.
- Badan Pusat Statistik Kota Bandung. (2019). *Kota Bandung Dalam Angka 2019*.
- Balmer, J. M. T., & Gray, E. R. (2003). Corporate brands: what are they? What of them? *European Journal of Marketing*, 37(7/8), 972–997.
- Caruana, A., & Ewing, M. T. (2010). How corporate reputation, quality, and value influence online loyalty. *Journal of Business Research*, 63(9–10), 1103–1110.
- Chahal, H., & Kumari, N. (2012). Consumer perceived value: The development of a multiple item scale in hospitals in the Indian context. *International Journal of Pharmaceutical and Healthcare Marketing*, 6(2), 167–190.
- Cojocaru, G. (2011). *Management Commitment to Service Quality, Job Embeddedness, and Performance Outcomes: A Study of Hotel Employees in Romania*. (June).
- Cronin Jr, J. J., & Taylor, S. A. (1992). Measuring service quality: a reexamination and extension. *Journal of marketing*, 56(3), 55–68.
- Cronin, J. J., & Taylor, S. A. (1994). SERVPERF versus SERVQUAL: Reconciling performance-based and perceptions-minus-expectations measurement of service quality. *Journal of Marketing*, 58(1), 125.
- Cronin Jr, J. J., & Taylor, S. A. (1992). Measuring service quality: a reexamination and extension. *Journal of Marketing*, 56(3), 55–68.
- Demirbag, M., Sahadev, S., Kaynak, E., & Akgul, A. (2012). Modeling quality commitment in service organizations: an empirical study. *European Journal of Marketing*, 46(6), 790–810.
- Hartline, M. D., & Ferrell, O. C. (1996). The management of customer-contact service employees: An empirical investigation. *Journal of marketing*, 60(4), 52–70.
- Heinberg, M., Ozkaya, H. E., & Taube, M. (2018). Do corporate image and reputation drive brand equity in India and China? - Similarities and differences. *Journal of Business Research*, 86(September), 259–268.
- Helm, S. (2011). Employees' awareness of their impact on corporate reputation. *Journal of Business Research*, 64(7), 657–

- 663.
- Herbig, P., & Milewicz, J. (1993). The Relationship of Reputation and Credibility to Brand Success. *Journal of Consumer Marketing*, 10(3), 18–24.
- Jalbani, S., & Soomro, N. (2017). Determinants of hotel's service standard: Reputation and relationship orientation. *Journal of Tourism & Hospitality*, 06(01), 1–7.
- Kurd, P., Medeni, T., Medeni, T., & Sagsan, M. (2017). Effects of occupational commitment on corporate reputation: An empirical test for a hospital case in North Cyprus. *International Journal of Organizational Leadership*, 6(1), 17–31.
- Liang, R.-D., Tseng, H.-C., & Lee, Y.-C. (2010). Impact of Service Orientation on Frontline Employee Service Performance and Consumer Response. *International Journal of Marketing Studies*, 2(2), 67–74.
- Lisch, R. (2014). Measuring Service Performance Practical Research for Better Quality. In *Routledge* (1st ed., Vol. 53).
- Lytle, R. S., & Timmerman, J. E. (2006). Service orientation and performance: An organizational perspective. *Journal of Services Marketing*, 20(2), 136–147.
- Minkiewicz, J., Evans, J., Bridson, K., & Mavondo, F. (2011). Corporate image in the leisure services sector. *Journal of Services Marketing*, 25(3), 190–201.
- Mmutle, T., & Shonhe, L. (2017). Customers' perception of service quality and its impact on reputation in the hospitality industry. *African Journal of Hospitality, Tourism and Leisure*, 6(3).
- Morgan, R. M., & Hunt, S. D. (1994). Theory of Relationship Marketing. *Journal of Marketing*, 58(3), 20–38.
- Parasuraman, A., Berry, L. L., & Zeithaml, V. A. (1991). Perceived service quality as a customer-based performance measure: An empirical examination of organizational barriers using an extended service quality model. *Human Resource Management*, 30(3), 335–364.
- Parasuraman, A., V. Z., & Berry, L. (1998). SERVQUAL: A multiple-item scale for measuring consumer perceptions of Service Quality. *Journal of Retailing*, 6(January), 12–37.
- Parasuraman, A., Zeithaml, V. A., & Berry, L. L. (1994). Reassessment of expectations as a comparison standard in measuring service quality: Implications for further research. *Journal of Marketing*, 58(1), 111.
- Parasuraman, A., Zeithaml, V. A., & Berry, L. L. (2010). *Model Service Its Quality and Implications for Future*. 49(4), 41–50.
- Park, E. (2019). Journal of retailing and consumer services corporate social responsibility as a determinant of corporate reputation in the airline industry. *Journal of Retailing and Consumer Services*, 47(November 2018), 215–221.
- Polnaya, I., Nirwanto, N., & Triatmanto, B. (2018). The evaluation of lecturer performance through soft skills, organizational culture and compensation on Private University of Ambon. *Academy of Strategic Management Journal*, 17(2), 1–9.
- PourKiani, M., & Tanabandeh, M. (2016). Explaining the relationship between management commitment to service quality, job satisfaction, and organizational performance in the staff of Islamic Republic of Iran's Custom. *International Journal of Humanities and Cultural Studies (IJHCS) ISSN 2356-5926*, 101–115.
- Resnick, J. T., & Resnick, J. T. (2012). *Corporate reputation: Managing corporate reputation ± applying rigorous measures to a key asset*. <https://doi.org/10.1108/02756660410569175>
- Roca-Puig, V., Beltran-Martin, I., & Segarra-Cipres, M. (2012). Commitment to employees, labor intensity, and labor productivity in small firms: a non-linear approach. *International Journal of Man*, 33(8), 938–954.
- Rod, M., & Ashill, N. J. (2010). Management commitment to service quality and service recovery performance: A study of frontline employees in public and private hospitals. *International Journal of Pharmaceutical and Healthcare Marketing*, 4(1), 84–103.
- Selnes, F. (1993). An examination of the effect of product performance on brand reputation, satisfaction and loyalty. *Journal of Product & Brand Management*, 2(4), 45–60.
- Suliman, A., & Al Kathairi, M. (2013). Organizational justice, commitment and performance in developing countries The case of the UAE. *Employee Relations*, 35, 98–115.
- Triatmanto, B., Wahyuni, N., & Respati, H. (2019). Continual Human Resources Empowerment through Human Capital and Commitment for the Organizational Performance in Hospitality Industry. *QUALITY Access to Success*, 20(173), 84–91. Retrieved from https://www.srac.ro/calitatea/en/arhiva/2019/QAS_Vol.20_No.173_Dec.2019.pdf
- Wang, Y. C., Qu, H., & Yang, J. (2019). The formation of sub-brand love and corporate brand love in hotel brand portfolios. *International Journal of Hospitality Management*, 77(July), 375–384. <https://doi.org/10.1016/j.ijhm.2018.08.001>
- Weiss, A. M., Anderson, E., & MacInnis, D. J. (1999). Reputation management as a motivation for sales structure decisions. *Journal of Marketing*, 63(4), 74–89. <https://doi.org/10.2307/1251975>



"The role of service performance mediating the effect of management commitment to service quality structure on the reputation of hospitality industry companies in West Java

ORIGINALITY REPORT

15%

SIMILARITY INDEX

7%

INTERNET SOURCES

9%

PUBLICATIONS

11%

STUDENT PAPERS

PRIMARY SOURCES

1	www.anzmac.org Internet Source	1%
2	Osman M. Karatepe. "The Effects of Involvement and Social Support on Frontline Employee Outcomes: Evidence From the Albanian Hotel Industry", International Journal of Hospitality & Tourism Administration, 2009 Publication	1%
3	P. K. Chang, H. L. Chong. "Customer satisfaction and loyalty on service provided by Malaysian telecommunication companies", Proceedings of the 2011 International Conference on Electrical Engineering and Informatics, 2011 Publication	1%
4	Submitted to London School of Commerce Student Paper	1%
5	Submitted to Maastricht School of Management	1%

6 Submitted to University of the Free State 1 %
Student Paper

7 docplayer.net 1 %
Internet Source

8 repository.fe.unj.ac.id 1 %
Internet Source

9 Submitted to Grand Canyon University 1 %
Student Paper

10 Paula Vicente, Ana Sampaio, Elizabeth Reis. 1 %
"Factors influencing passenger loyalty
towards public transport services: Does public
transport providers' commitment to
environmental sustainability matter?", Case
Studies on Transport Policy, 2020
Publication

11 British Food Journal, Volume 114, Issue 6 1 %
(2012-06-19)
Publication

12 Yosef Tonce, Achmad Firdiansjah, Junianto 1 %
Tjahjo Darsono. "The Effect of Price
Perceptions and Product Quality on Interest
and its Impact on Purchase Decision Fabric
Glove Sikka Motive in Maumere",
International Journal of Advances in Scientific
Research and Engineering, 2020
Publication

13	Submitted to Multimedia University Student Paper	<1 %
14	www.tandfonline.com Internet Source	<1 %
15	Submitted to Universitas Jenderal Soedirman Student Paper	<1 %
16	"Complex, Intelligent and Software Intensive Systems", Springer Science and Business Media LLC, 2021 Publication	<1 %
17	Marco Ferretti, Giorgia Profumo, Ilaria Tutore. "Shock events and corporate announcements", Journal of Communication Management, 2015 Publication	<1 %
18	Submitted to University of Alabama at Birmingham Student Paper	<1 %
19	Xiaolin Hu, Jinzhi Gao, Xiaoping Luo, Ling Feng, Weiyong Liu, Juan Chen, Alexandra Benachi, Daniele De Luca, Ling Chen. "Severe Acute Respiratory Syndrome Coronavirus 2 (SARS-CoV-2) Vertical Transmission in Neonates Born to Mothers With Coronavirus Disease 2019 (COVID-19) Pneumonia", Obstetrics & Gynecology, 2020 Publication	<1 %

20	doaj.org Internet Source	<1 %
21	Submitted to The Hong Kong Polytechnic University Student Paper	<1 %
22	id.scribd.com Internet Source	<1 %
23	www.emrbi.org Internet Source	<1 %
24	www.onlinemarketingseo.com Internet Source	<1 %
25	Ardiani Ika Sulistyawati, Aprih Santoso, Liana Rokhawati. "DETERMINANT DETECTION OF TRANSFER PRICING DECISIONS", ACCOUNTABILITY, 2020 Publication	<1 %
26	Marselinus Reo Due, Fajar Supanto, Rudy Wahyono. "The Effect of Principal Leadership, Teacher Performance and Learning Facilities on Student Achievement in SMPN 1 Kepanjen Malang, Indonesia", International Journal of Advances in Scientific Research and Engineering, 2020 Publication	<1 %
27	Submitted to University of Hull Student Paper	<1 %

28	pt.scribd.com Internet Source	<1 %
29	repository.up.ac.za Internet Source	<1 %
30	shareok.org Internet Source	<1 %
31	www.moray.gov.uk Internet Source	<1 %
32	E. Tsitskari, D. Tsiotras, G. Tsiotras. "Measuring service quality in sport services", Total Quality Management & Business Excellence, 2006 Publication	<1 %
33	Submitted to Mahidol University Student Paper	<1 %
34	Submitted to University of Strathclyde Student Paper	<1 %
35	Wiesław Urban. "SERVICE QUALITY GAPS AND THEIR ROLE IN SERVICE ENTERPRISES DEVELOPMENT", Technological and Economic Development of Economy, 2009 Publication	<1 %

Exclude bibliography On